

ZFV VISION SENSOR

Easy vision - Teach & Go



» Scalable and flexible

» Easy colour vision

» Intuitive in use

Advanced Industrial Automation

OMRON

A true “Easy vision – Teach & Go” vision sensor

Omron’s ZFV is an innovative image-processing system in a sensor format. What makes this sensor so special is how easy it is to use; with its ‘Teach & Go’ concept you can configure an inspection routine in just a few steps using the sensor’s integrated, high-resolution colour LCD screen and simple menu system. The screen provides live image display during set-up and operation, and gives you instant feedback during the inspection process. And a choice of controllers gives you the tools to perform everything from simple presence detection to advanced pattern recognition.

Colour and grey scale versions available

The latest addition to the ZFV family is the ZFV Colour sensor. Using this instead of the conventional monochrome sensor widens the choice of applications and increases the stability of measurement of the inspection. Through its automatic colour filter function, image contrast is optimised, making inspections more reliable. There are seven colour filters in total; the one that obtains the most suitable contrast can be automatically selected, so there’s no need to worry about colour setting parameters.



Target - Teach - Go!

Set-up in minutes

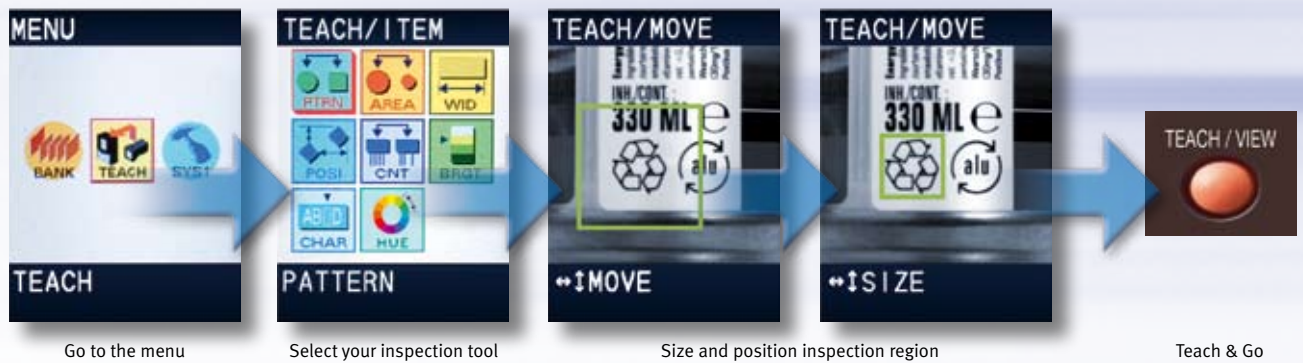

Intuitive user interface

The ZFV's user interface is smart! You can set parameters using a few buttons and the integrated LCD colour monitor. Operation menus and icons guide you through a simple set-up process. During operation, the LCD screen enables you to see results and images in real-time. There's no need to connect an external PC for set-up, maintenance or operation viewing; the ZFV supplies real-time images all the time. The ZFV provides instant feedback - on board - exactly when you need it.

Your benefit: No expert knowledge required, minimised downtime for setup and maintenance.



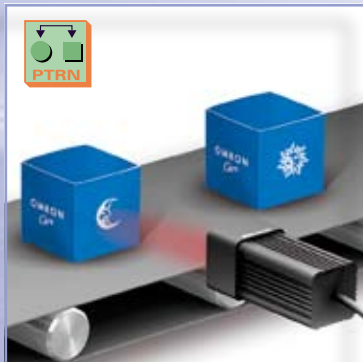

Pattern recognition

This tool verifies if a symbol printed on a package is present and complete using a taught feature as a reference.



Hue verification

The Hue tool inspects colour differences in a plain colour work-piece. A false colour cap will be rejected.



Width inspection

The Width tool measures an object, in this case a label, to verify that it is not folded or cut.

Multiple functions: "One Sensor Fits All" concept

Depending on the controller version, the ZFV contains up to 8 different tools; one can be selected at a time. These sophisticated tools offer an affordable sensor with a very intuitive user interface. Both the monochrome and colour version offer basically the same inspection functionality while the ZFV Colour uses the additional colour information included in the image. The tools include:



Counting (number): uses Edge Count to count the number of object edges.



Brightness: verifies objects using density average and deflection.



Pattern (shape): recognises objects by the difference of pattern and presence of pattern.



Width: measures the width of an object using Edge Tool.



Area (size): verifies an object using size (pixel count).



Character (text): inspects one character and the presence of a character string.



Position: verifies the position of an object using Edge Tool.



Hue: checks the difference between the measured colour and a reference colour (Colour version only).

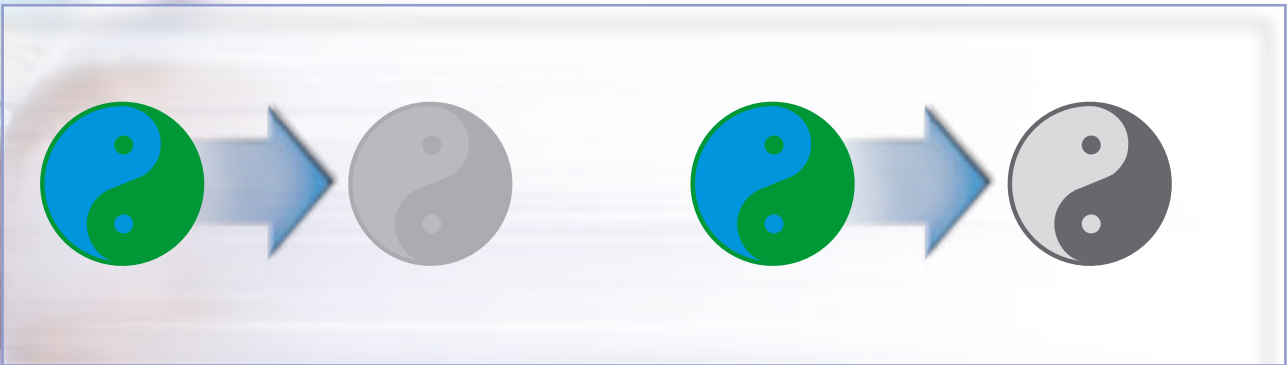

This is what a grey scale sensor sees

That is what a monochrome sensor sees using red light. Depending on the object colour or object colour mix, the image contrast can be very weak.

This is what the ZFV Colour sees

The ZFV acquires a colour image, applies a colour filter and processes the resulting image. Image contrast is significantly increased.

Colour can be the difference

The monochrome version of the ZFV will be a perfect solution for all your easy vision tasks - as long as the object colours still provide enough image contrast. If that is not the case, use the ZFV Colour. As it acquires a colour image, it uses the colour information as a “virtual 3rd dimension” - adding security and reliability to your application.

Get the colours right

Through its automatic colour filter function, the ZFV Colour is able to see and inspect multi-coloured objects invisible for a grey scale sensor. Use the seven integrated colour filters and the colour pickup function to get the right contrast or extract only the relevant colour from the image– by using colour information, you simply “get the image good”.



Character

This tool verifies if a lot code, date code or product code is entirely printed on a label.





Scale it to your needs

You can set-up one inspection per controller – but the ZFV is scalable, so you can simply add controllers as required by connecting them to a common communication bus to expand the functionality of your sensor. Up to five controllers can be connected together through a simple snap-on system to perform multiple inspections on your work-piece. Other option modules, like the data storage unit (DSU) for data logging, can also be added to enhance communication and data storage functionality. Your benefit: You protect your investment; the sensor will grow with your requirements.

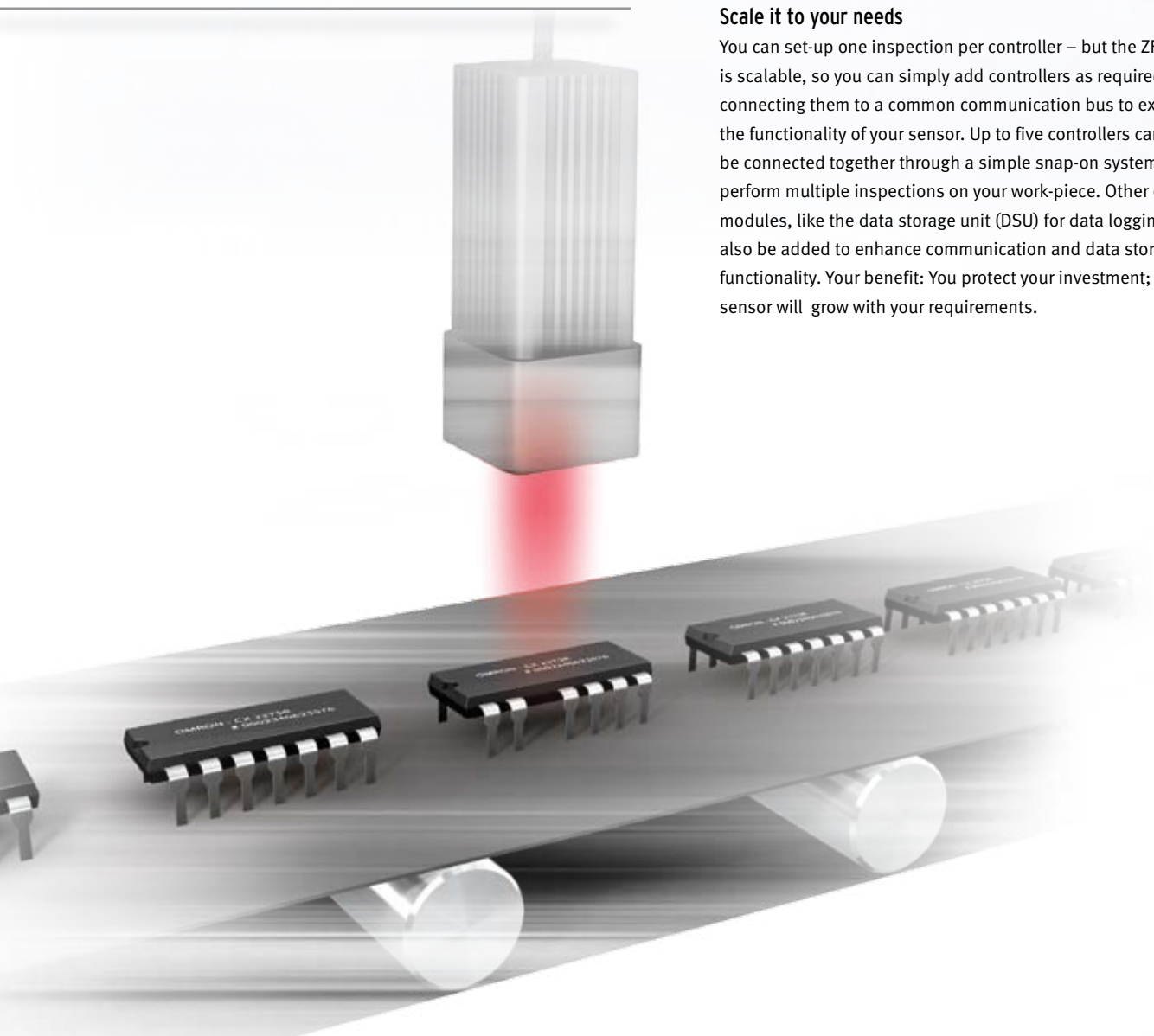

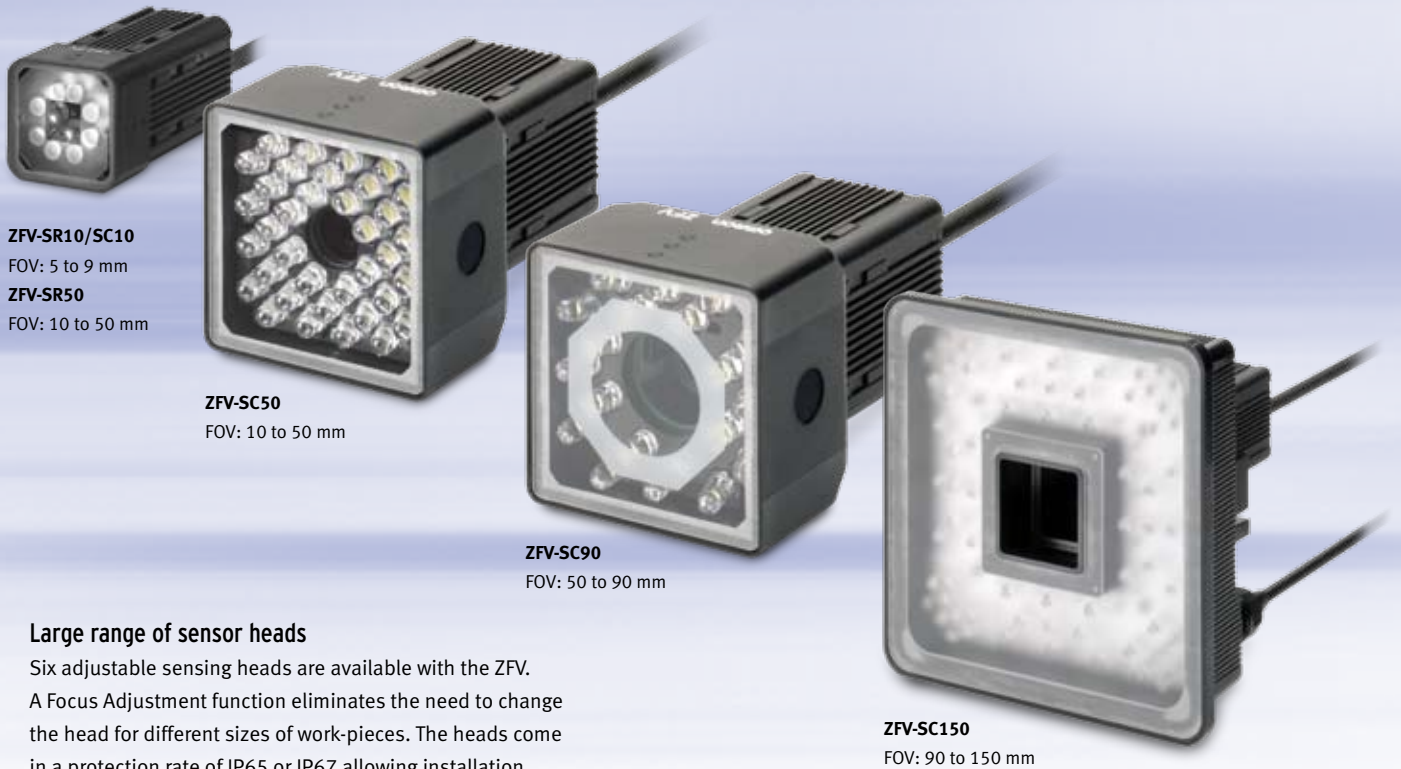

ZFV-SR10/SC10

FOV: 5 to 9 mm

ZFV-SR50

FOV: 10 to 50 mm

ZFV-SC50

FOV: 10 to 50 mm

ZFV-SC90

FOV: 50 to 90 mm

ZFV-SC150

FOV: 90 to 150 mm

Large range of sensor heads

Six adjustable sensing heads are available with the ZFV. A Focus Adjustment function eliminates the need to change the head for different sizes of work-pieces. The heads come in a protection rate of IP65 or IP67 allowing installation in harsh environments.

Light intensity and direction can be adjusted manually or switched off if an external light source is more appropriate. The range of detection heads is now larger than ever before, extending the field of view to 150 mm. This enables you to inspect even large work-pieces that previously could not be handled. Your benefit: Minimised investment cost due to the "one sensor fits all concept".



Easy meets advanced

The sensor keeps all settings for up to 8 configurations in an internal memory. If that is not enough or if you want to log or communicate results and settings, simply connect the optional data storage unit to either the grey scale or colour version.

The ZFV Colour also features USB and RS-232C interfaces for connection to a personal computer, enabling the easy transfer of data and results. Remote configuration software will be available later this year enabling you to remotely set-up and maintain your sensor.

Smart Vision Sensors

ZFV Gray Scale/Colour Series



Ordering Information

Models ZFV Gray Scale Series

Sets of Sensor Head and Amplifier Unit

Type	NPN	PNP
Narrow View/Single Function	ZFV-R1010	ZFV-R1015
Narrow View/Standard	ZFV-R1020	ZFV-R1025
Wide View/Single Function	ZFV-R5010	ZFV-R5015
Wide View/Standard	ZFV-R5020	ZFV-R5025

Sensor Heads

Appearance	Type	Setting distance	Sensing area	Model
	Narrow View	34 to 49 mm (variable)	5 x 4.6 mm to 9 x 8.3 mm (variable)	ZFV-SR10
	Wide View	38 to 194 mm (variable)	10 x 9.2 mm to 50 x 46 mm (variable)	ZFV-SR50

Models ZFV Colour Series

Sensor Heads

Appearance	Type	Setting distance	Sensing area	Model
	Narrow View	34 to 49 mm (variable)	5 x 4.6 mm to 9 x 8.3 mm (variable)	ZFV-SC10
	Standard View	31 to 187 mm (variable)	10 x 9.2 mm to 50 x 46 mm (variable)	ZFV-SC50
	Wide View	66 to 141 mm (variable)	50 x 46 mm to 90 x 83 mm (variable)	ZFV-SC90
	Ultra-wide View	114 to 226 mm (variable)	90 x 83 mm to 150 x 138 mm (variable)	ZFV-SC150

Amplifier Units ZFV Gray Scale Series

Appearance	Type	Power supply	Output type	Model
	Single Function	24 VDC	NPN	ZFV-A10
			PNP	ZFV-A15
	Standard		NPN	ZFV-A20
			PNP	ZFV-A25

Amplifier Units ZFV Colour Series

Appearance	Power supply	Output type	Model
	24 VDC	NPN	ZFV-CA40
		PNP	ZFV-CA45

Common Accessories ZFV Gray Scale/Colour Series (order separately)

Data Storage Units

Appearance	Power supply	Output type	Model
	24 VDC	NPN	ZS-DSU11
		PNP	ZS-DSU41

Sensor Head Extension Cable

Cable length	Model
3 m	ZFV-XC3B *1
8 m	ZFV-XC8B

*1: ZFV-XC3BR Robot Cable is also available.

Controller Link Unit

Appearance	Model
	ZS-XCN

Panel-mounting Adapter

Appearance		
Model	ZS-XOM1	ZS-XPM2
	First Unit	Additional Units (for expansion)

Specifications ZFV Gray Scale Series

Sensor Heads

Item	ZFV-SR10 (Narrow View)	ZFV-SR50 (Wide View)
Setting distance (L)	34 to 49 mm	38 to 194 mm
Detection range (H × V)	5 × 4.6 mm to 9 × 8.3 mm	10 × 9.2 mm to 50 × 46 mm
Relation between setting distance and detection range		
Guide light	Provided (center, sensing area)	
Built-in lens	Focus: f15.65	Focus: f13.47
Object lighting method	Pulse lighting	
Object light source	Eight red LEDs	
Sensing element	1/3-inch CCD, partial scan	
Shutter	Electronic shutter, shutter time: 1/1,000 to 1/4,000	
Power supply voltage	15 VDC (Supplied from Amplifier Unit.)	
Current consumption	Approx. 200 mA	
Vibration resistance (destruction)	10 to 150 Hz, 0.35-mm single amplitude, 10 times each in X, Y, and Z directions for 8 min	
Shock resistance (destruction)	150 m/s ² , three times each in six directions (up/down, left/right, forward/backward)	
Connection method	Prewired, Standard cable length: 2 m	
Degree of protection	IEC60529, IP65	

Amplifier Units

Item	Single-function Models		Standard Models	
	ZFV-A10	ZFV-A15	ZFV-A20	ZFV-A25
Output method	NPN	PNP	NPN	PNP
Inspection items	Pattern (PTRN), Brightness (BRGT)		Patterns (PTRN), Brightness (BRGT), Area (AREA), Width (WID), Position (POS), Count (CNT), Characters (CHAR)	
Teaching area	Rectangular, one area			
Teaching area size	Pattern (PTRN), Brightness (BRGT): Any rectangular area (256 × 256 max.) Area (AREA), Width (WID), Position (POS), Count (CNT), Characters (CHAR): Any rectangular area (full screen max.)			
Sensing area	Full screen			
Resolution	468 432 (H V) max.			
Bank selection	Supported for 8 banks.			
Response time	Pattern (PTRN), Brightness (BRGT): High-speed: 4 ms, Standard: 8 ms, High-precision: 12 ms (not using partial scan) Area (AREA), Width (WID), Position (POS), Count (CNT), Characters (CHAR): 128 128: 15 ms max.			
Other functions	Control output switching: ON for OK or ON for NG ON delay/OFF delay, One-shot output, "ECO" mode			
Output signals	(1) Control output (OUTPUT), (2) Enable output (ENABLE), (3) Error output (ERROR)			
Input signals	(1) Simultaneous measurement input (TRIG) or Continuous measurement input (TRIG), Switched by using menu. (2) Bank selection inputs (BANK1 to BANK3) (3) Workpiece still teaching (TEACH) or Workpiece moving teaching (TEACH), Switched by using menu.			
Sensor Head interface	Digital interface			
Image display	Compact TFT 1.8-inch LCD (Display dots: 557 234)			
Indicators	Judgement result indicator (OUTPUT) Inspection mode indicator (RUN)			
Operation interface	Cursor keys (up, down, left, right) Setting key (SET) Escape key (ESC) Operating mode switching (slide switch) Menu switching (slide switch) Teaching/Display switching key (TEACH/VIEW)			
Power supply voltage	20.4 to 26.4 VDC (including ripple)			
Current consumption	600 mA max. (with Sensor Head connected)			
Degree of protection	IEC60529, IP20			

Specifications ZFV Colour Series

Sensor Heads

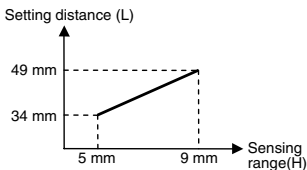
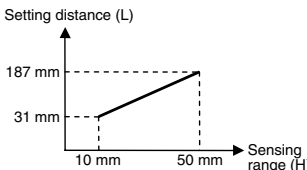
Item	ZFV-SC10 (Narrow View)	ZFV-SC50 (Wide View)
Setting distance (L)	34 to 49 mm (variable)	31 to 187 mm (variable)
Sensing range (H × V)	5 × 4.6 mm to 9 × 8.3 mm (variable)	10 × 9.2 mm to 50 × 46 mm (variable)
Relation between setting distance and detection range		
Built-in lens	Focus: f15.65	Focus: f13.47
Object lighting method	Pulse lighting	
Object light source	Eight white LEDs	Thirty-six white LEDs
Laser class ^{*1}	Class 1	Class 2
External lighting interface	No	Yes
Sensing element	1/3-inch CCD	
Shutter	Electronic shutter, shutter time: 1/500 to 1/8,000	
Power supply voltage	15 VDC (Supplied from Amplifier Unit.)	
Current consumption	Approx. 200 mA	Approx. 350 mA (15 V: approx. 150 mA, 48 V: approx. 200 mA, including current when external light is connected)
Vibration resistance (destruction)	10 to 150 Hz, 0.35 mm single amplitude, 10 times each in X, Y, and Z directions for 8 min	
Shock resistance (destruction)	150 m/s ² , three times each in six directions (up/down, left/right, forward/backward)	
Connection method	Prewired, Standard cable length: 2 m	
Degree of protection	IEC 60529, IP65	IEC 60529, IP65 ^{*2}

^{*1}: Applicable standards: IEC 60825-1: 1993, +A1: 1997, +A2: 2001, EN 60825-1: 1994, +A1: 2002, +A2: 2001

^{*2}: Consult your OMRON representative if IP67 protection is required.

Note: More colour heads are available. Please contact your OMRON dealer for the full range of ZFV-SC heads.

Amplifier Units

Item	ZFV-CA40	ZFV-CA45
Output method	NPN open collector, 30 VDC 50 mA max., residual voltage 1.2 V max.	PNP open collector, 50 mA max., residual voltage 1.2 V max.
Serial I/O	USB2.0 1 port, full-speed (12 Mbps) MINI-B RS-232C 1 port, 115200 bps max.	
Inspection items	Patterns (PATTERN), Brightness (BRIGHT), Area (AREA), Width (WIDTH), Position (POSITION), Count (COUNT), Colour inspection (HUE)	
Teaching area size	<ul style="list-style-type: none"> • Patterns (PATTERN), Brightness (BRIGHT): Any rectangular area (256 × 256 max.) • Area (AREA), Width (WIDTH), Position (POSITION), Count (COUNT), Colour inspection (HUE): Any rectangular area (full screen max.) 	
Sensing area	Full screen	
Resolution	468 x 432 (H x V) max.	
Bank selection	Supported for 8 banks.	
Image input cycle	13 ms (Standard), 8 ms (FAST mode), 5 ms (MAX mode)	
Other functions	Control output switching: ON for OK or ON for NG, ON delay/OFF delay, One-shot output, "ECO" mode	
Connecting to ZS-DSU	Image logging trigger	Stores NG images or all images.
	Sampling rate	ZFV measurement cycle ^{*1}
	Number of logged images	Logs up to 128 images in series
	Number of connected Units	15 max. (ZFV: 5 Units max.)
External bank function	Amplifier Unit setting data can be saved to the memory card as bank data. Reading bank data enables bank switching.	
Output signals	(1) Control output (OUTPUT) (2) Enable output (ENABLE) (3) Error output (ERROR)	
Input signals	(1) Sync measurement input (TRIG)/Continuous measurement input (TRIG); switched from menu (2) Bank selection input (BANK1-3) (3) Object stationary teaching (TEACH)/Object motion teaching (TEACH); switched from menu	
Sensor Head interface	Digital interface	
Image display	TFT 1.8-inch LCD (Display dots: 557 x 234)	
Indicators	<ul style="list-style-type: none"> • Judgment result indicator (OUTPUT, Colour: orange) • Inspection mode indicator (RUN, Colour: green) • Error indicator (ERR, Colour: red) • Ready status indicator (READY, Colour: blue) 	
Operation interface	<ul style="list-style-type: none"> • Cursor keys (up, down, left, right) • Setting key (SET) • Escape key (ESC) • Operating mode switching (slide switch) • Menu switching (slide switch) • Teaching/Display switching key (TEACH/VIEW) • Function keys (A to D, 4 inputs) 	
Power supply voltage	20.4 to 26.4 VDC (including ripple)	
Current consumption	800 mA max. (with Sensor Head connected)	
Degree of protection	IEC 60529, IP20	

^{*1}: This is the sampling rate when logging images. To log measurement data only, use the ZS-DSU settings.

Dimensions

Sensor Heads

- ZFV-SR10
- ZFV-SC10
- ZFV-SR50

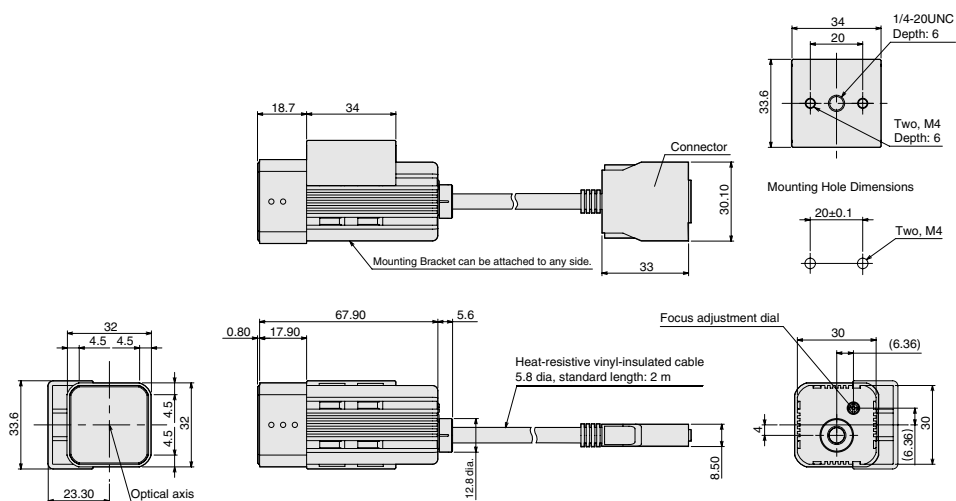

ZFV-SC50

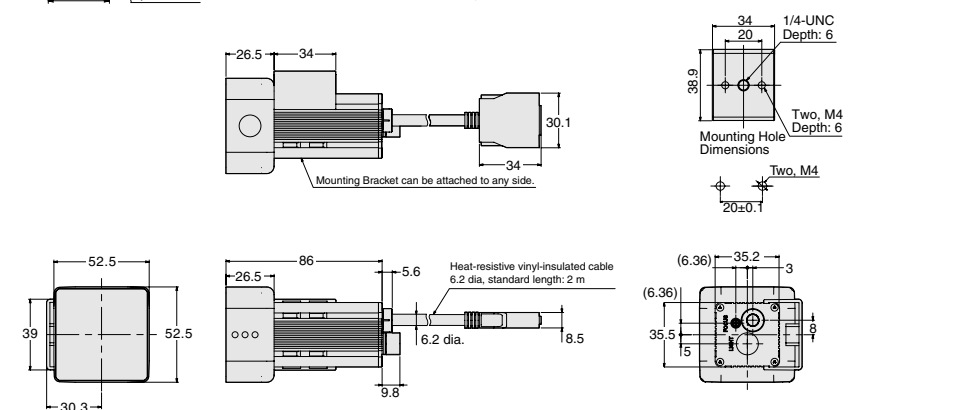

More colour heads are available. Please contact your OMRON dealer for the full range of ZFV-SC heads.

Amplifier Units

ZFV-CA4□

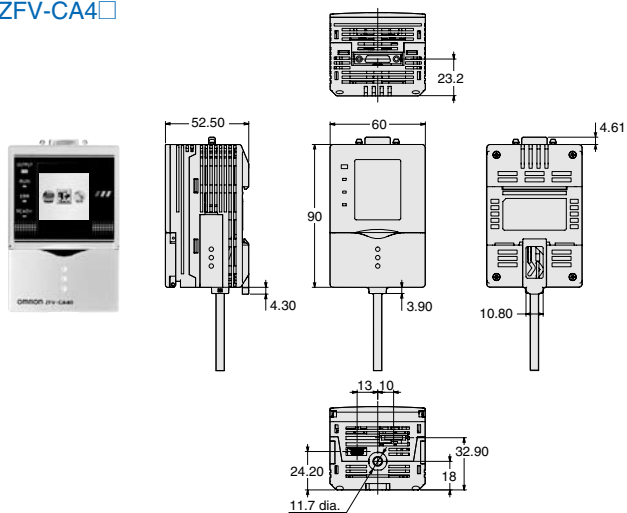

ZFV-A□

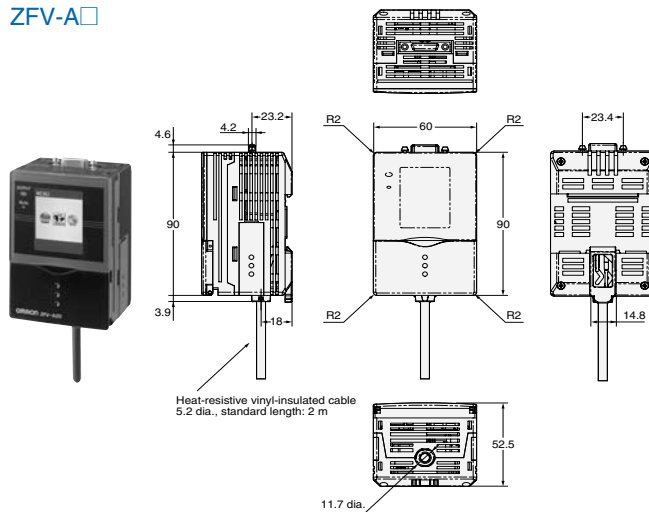

For full specifications and additional models please refer to www.omron-industrial.com
 Vision sensors - Cat.-No. Z205-E2-02A-X (ZFC Gray Scale Series) and E373-E2-01-X (ZFV Colour Series)

never fail?
never fail!

Inspect smarter... You can rely on it!

www.never-fail.info

- Vision demonstrated live
- Inspiring applications



OMRON EUROPE B.V. Wegalaan 67-69, NL-2132 JD, Hoofddorp, The Netherlands. Tel: +31 (0) 23 568 13 00 Fax: +31 (0) 23 568 13 88 www.omron-industrial.com

Austria

Tel: +43 (0) 1 80 19 00
www.omron.at

Belgium

Tel: +32 (0) 2 466 24 80
www.omron.be

Czech Republic

Tel: +420 234 602 602
www.omron.cz

Denmark

Tel: +45 43 44 00 11
www.omron.dk

Finland

Tel: +358 (0) 207 464 200
www.omron.fi

France

Tel: +33 (0) 1 56 63 70 00
www.omron.fr

Germany

Tel: +49 (0) 2173 680 00
www.omron.de

Hungary

Tel: +36 (0) 1 399 30 50
www.omron.hu

Italy

Tel: +39 02 326 81
www.omron.it

Middle East & Africa

Tel: +31 (0) 23 568 11 00
www.omron-industrial.com

Netherlands

Tel: +31 (0) 23 568 11 00
www.omron.nl

Norway

Tel: +47 (0) 22 65 75 00
www.omron.no

Poland

Tel: +48 (0) 22 645 78 60
www.omron.pl

Portugal

Tel: +351 21 942 94 00
www.omron.pt

Russia

Tel: +7 495 745 26 64
www.omron.ru

Spain

Tel: +34 913 777 900
www.omron.es

Sweden

Tel: +46 (0) 8 632 35 00
www.omron.se

Switzerland

Tel: +41 (0) 41 748 13 13
www.omron.ch

Turkey

Tel: +90 (0) 216 474 00 40
www.omron.com.tr

United Kingdom

Tel: +44 (0) 870 752 08 61
www.omron.co.uk

More Omron representatives
www.omron-industrial.com

Authorised Distributor:

Control Systems

- Programmable logic controllers • Human-machine interfaces • Remote I/O

Motion & Drives

- Motion controllers • Servo systems • Inverters

Control Components

- Temperature controllers • Power supplies • Timers • Counters • Programmable relays
- Digital panel indicators • Electromechanical relays • Monitoring products • Solid-state relays
- Limit switches • Pushbutton switches • Low voltage switch gear

Sensing & Safety

- Photoelectric sensors • Inductive sensors • Capacitive & pressure sensors • Cable connectors
- Displacement & width-measuring sensors • Vision systems • Safety networks • Safety sensors
- Safety units/relay units • Safety door/guard lock switches